

10 Schematic Diagram

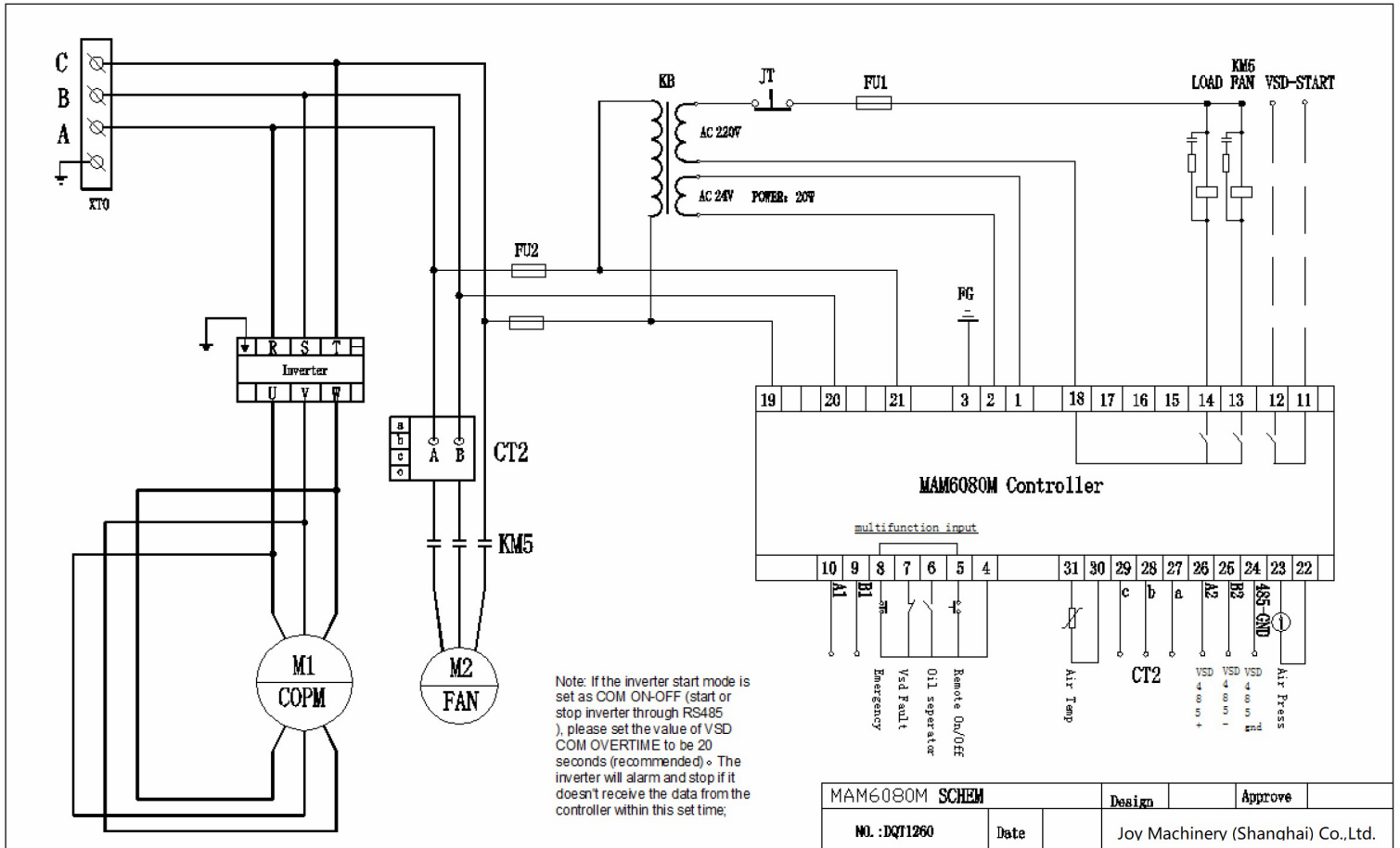

Appendix: Output Mode Introduction:

We add 4 control mode options to controller 6080、6090、6070. User can choose to open or close this function. The introduction is shown as below:

Turn on “output option” in motor VSD parameter, than menu selection interface will increase “output option”. Shown as below:

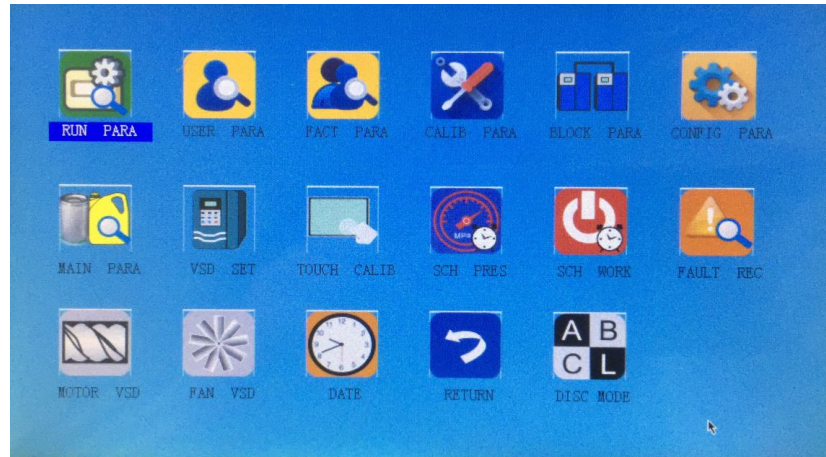

Click “output option” and enter the interface as shown in the below. Users can choose the proper speed adjustment mode according to their needs.

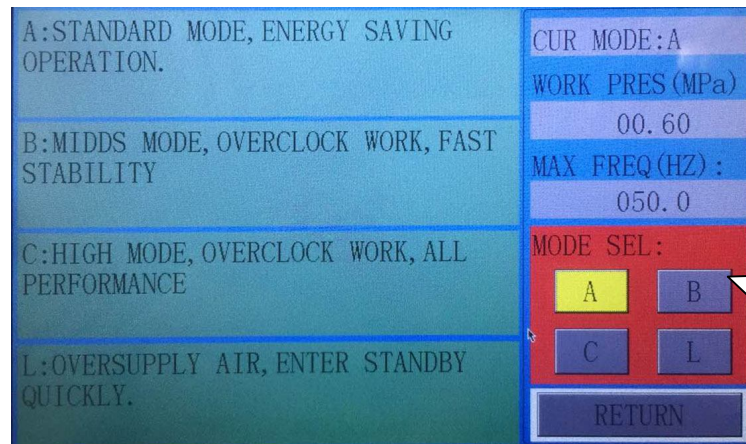

When the “Mode” is closed here, need to open “output option” in motor VSD parameter

- Mode A: In this mode, the motor is speeded up to motor rated frequency according to inverter maximum acceleration performance after start. After running for some time, pressure is close to constant pressure, then to judge whether brake intelligently according to pressure rise speed, and stabilize pressure to a constant pressure point in one time. (the old version software adopts the model)
- Mode B: (Overclocking operation) In this mode, the motor is speeded up to the corresponding frequency value according to constant power pressure point set by users after start. After running for some time, pressure is close to constant pressure, then to judge whether brake intelligently according to pressure rise speed, and stabilize pressure to a constant pressure point in one time.

(New mode 1)

- Mode C :(Overclocking and high speed operation). In this mode, the motor is speeded up to the corresponding frequency value according to constant power pressure point set by users after start. Make fastest air output. This mode will take full advantage of the air compressor. (New mode 2)
- Mode L: This mode, based on the mode A, to reduces the running time in low frequency and to achieve the best energy saving effect. (New mode 3)