

10,Schematic Diagram

10.1,PF

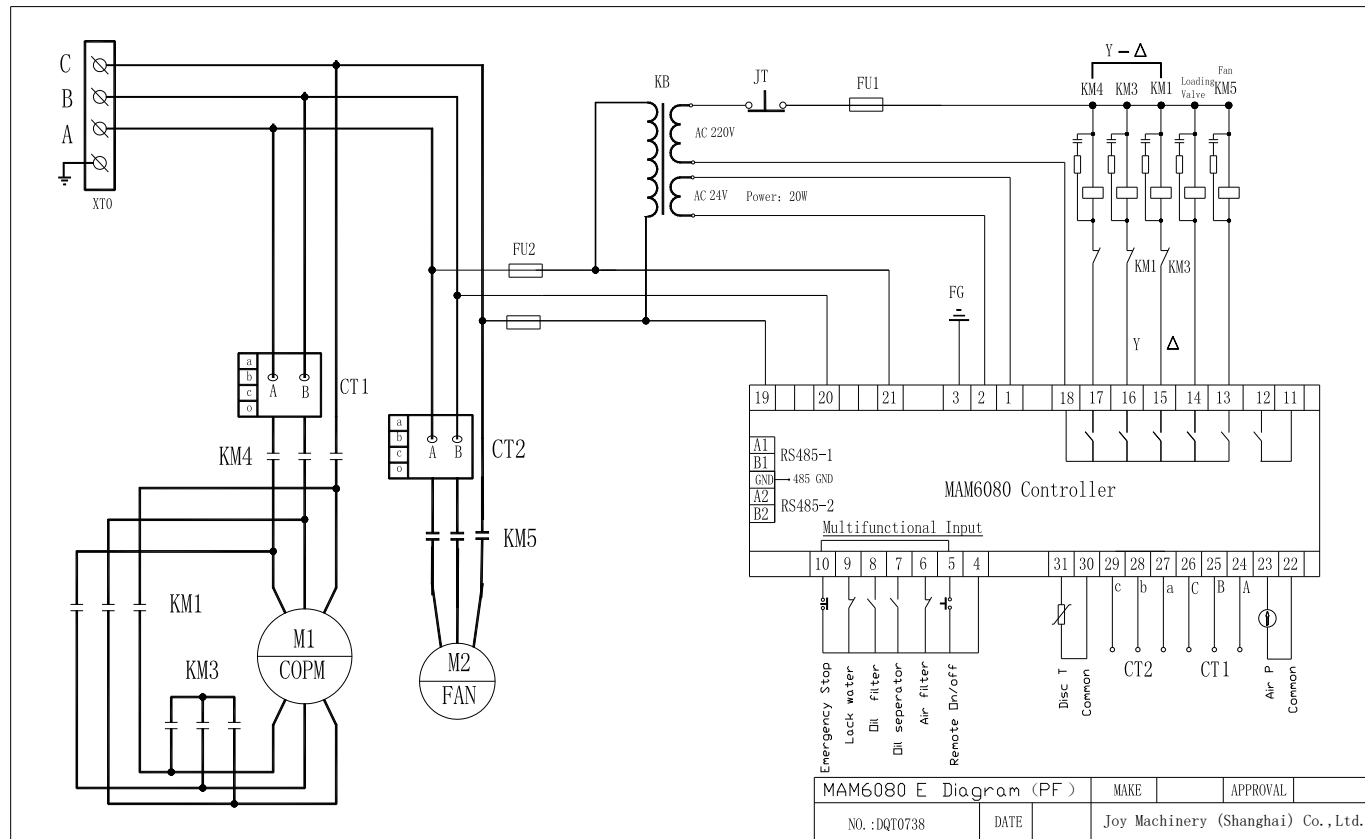

10.2,PERM MAGNET VSD, MOTOR VSD

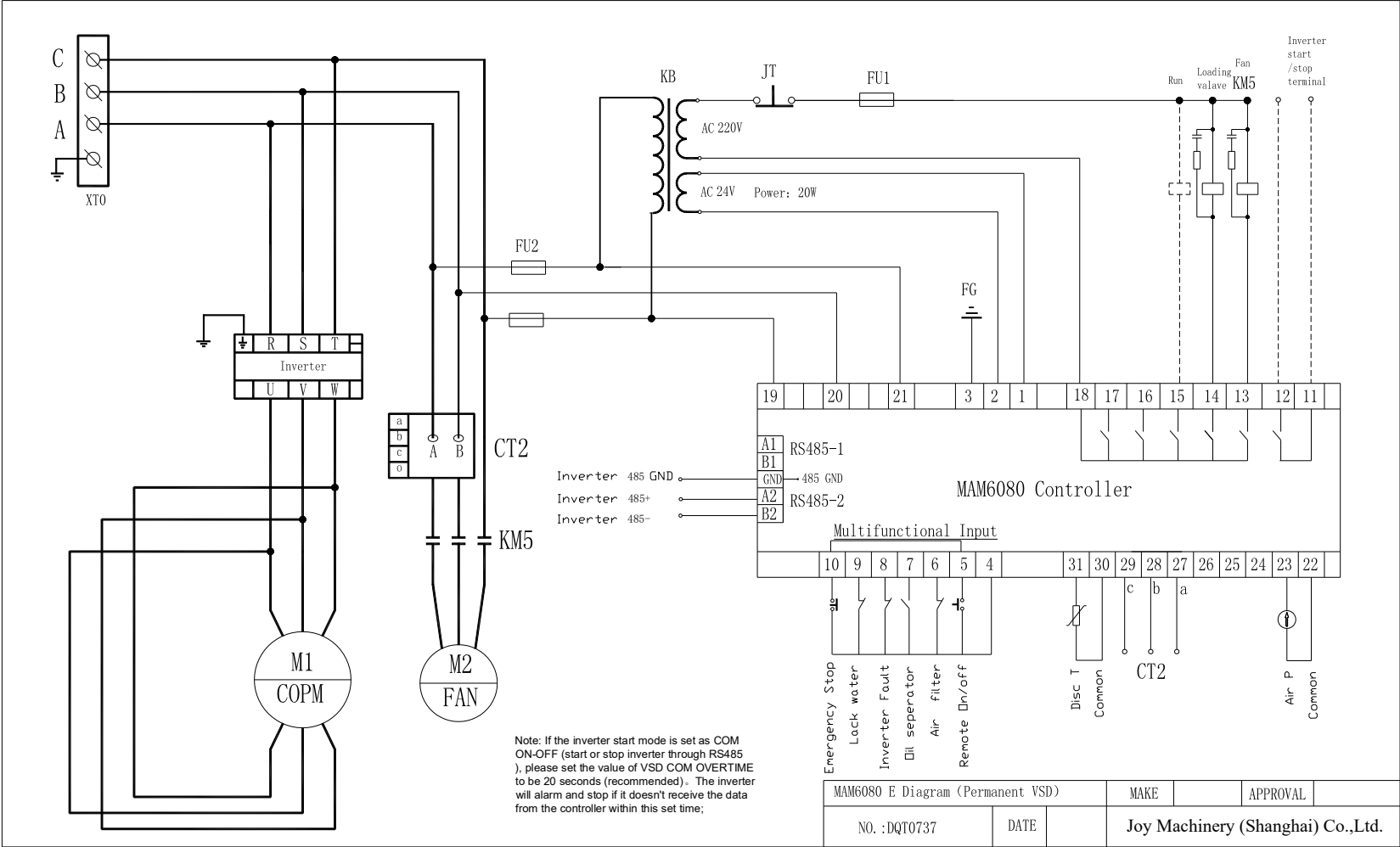

10.3,PF/VSD

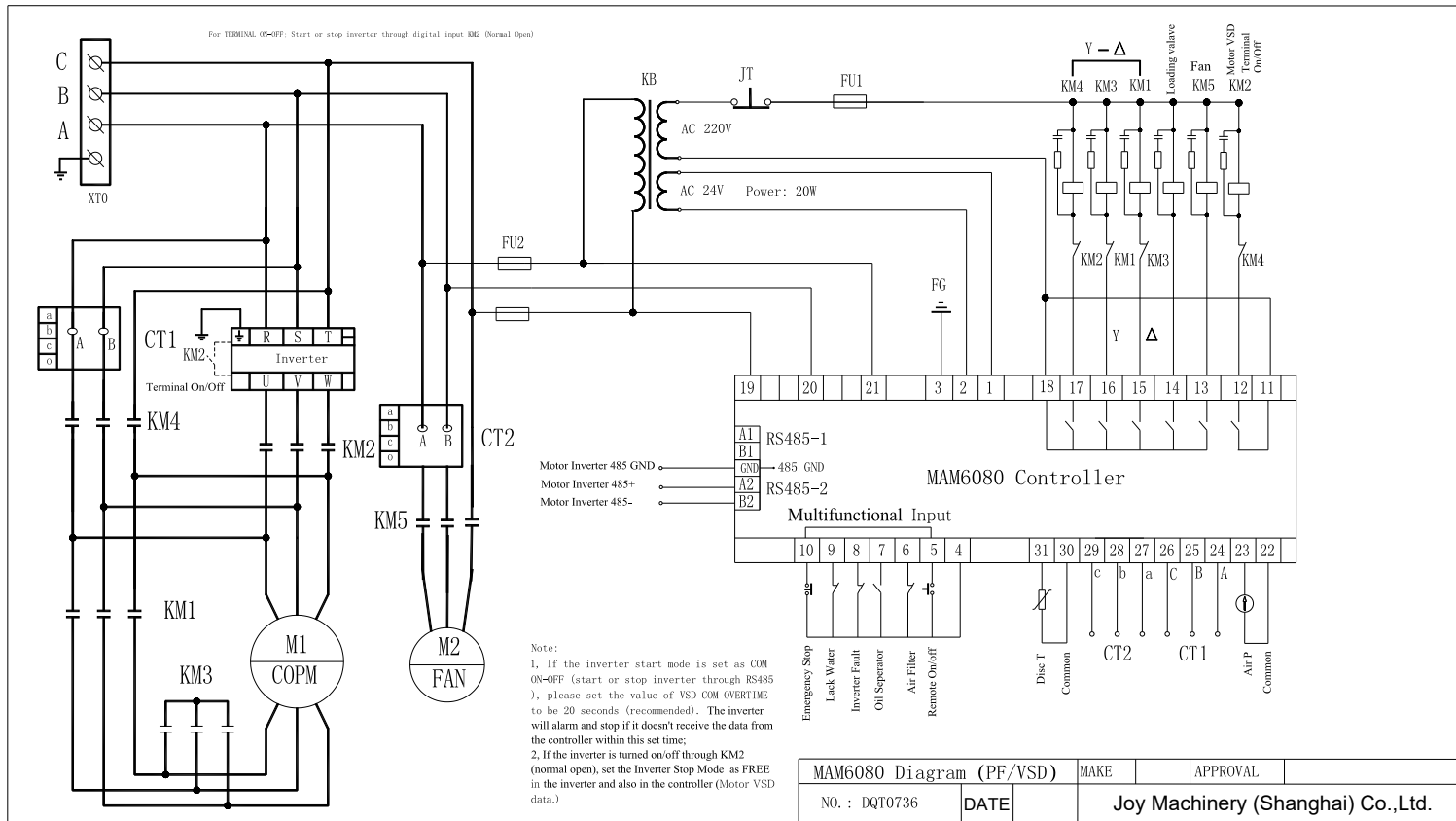

10.4,FAN VSD

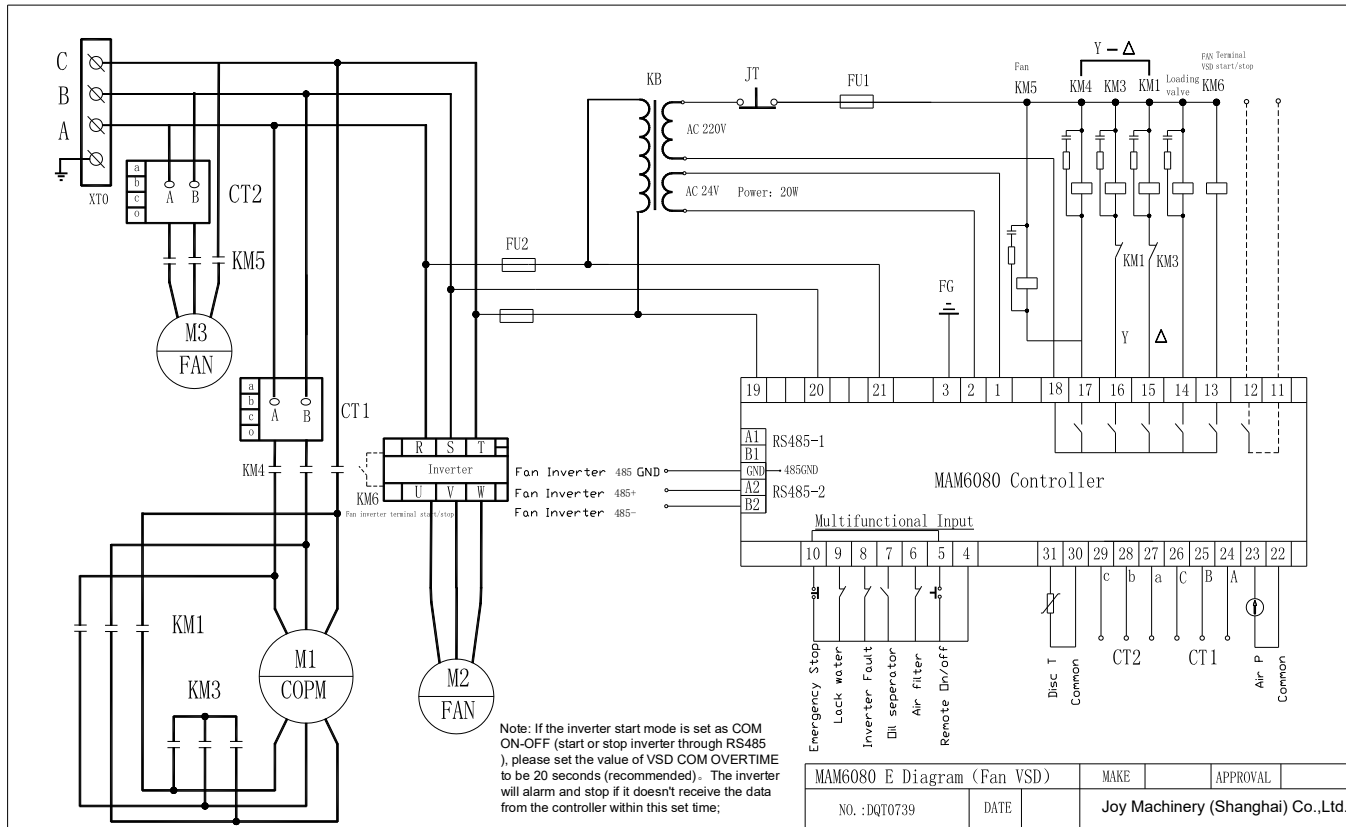

10.5, MOTOR FAN VSD

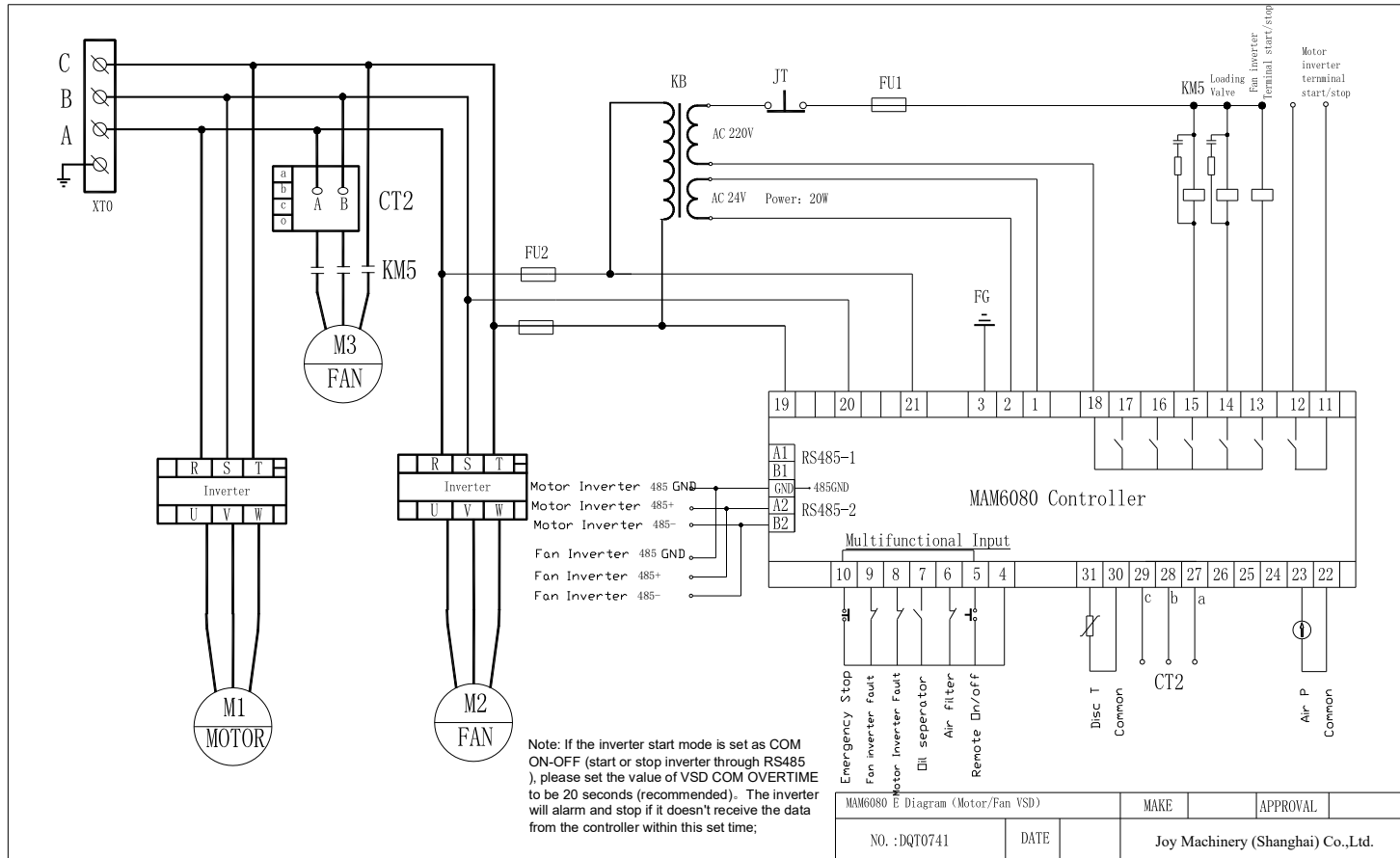

10.6,Soft Start

